

- **8 or 16 Outputs**
- **Transistor or Relay Options**
- **Transistor Outputs are Rated for 500 mA @ 24 VDC**
- **Relay Outputs are Rated for 2 A @ 30 VDC or 250 VAC**
- **Transistor Outputs are Opto-isolated**
- **LED Display to Monitor Running Conditions**
- **Easy Maintenance and Installation**



The K622 Discrete Output Expansion Modules are offered in Transistor or Relay and 8 or 16 outputs. These modules are attached to the K6 CPUs to expand beyond the onboard outputs. The K6 CPUs can handle up to 264 I/O points with a maximum of 14 expansion modules. If a user were to select the K608-40AT along with 6 K622-16DT units, the user would achieve the maximum 264 I/O points within the constraint of 6 expansion modules. The K622-__DT modules come with transistor outputs with a sourcing configuration. A sourcing output is internally pulled down to ground; the current wants to flow into the output. The K622-__XR modules come with relay outputs that can handle loads up to 30 VDC and 250 VAC. Relay outputs are great to drive AC or DC motors or turn any AC or DC device on. The transistor output modules are opto-isolated for unit protection.

Parameter	K622-08DT	K622-16DT	K622-08XR	K622-16XR
Output Points	8	16	8	16
Output Type	Transistor (Sourcing)		Relay	
Output Voltage	Rated: 24 VDC Allowable Range: 20.4 - 28.8 VDC		Max 30 VDC or Max 250VAC	
Output Current/ Channel	500 mA @ 24 VDC		2 A @ 30 VDC or 250 VAC	
Output Off-to-On Delay	----		Max 10 ms	
Output On-to-Off Delay	----		Max 5 ms	
Isolation Mode	Opto-Electrical Isolation Between Input Signal and Internal Circuit		Relay	
Isolation Voltage	500 VAC / 1 Minute		2,000 Vrms Between Coil and Contact 1,000 Vrms Between Contacts	
Signal Identification	Separate LED Indicators for Each Channel			
Module Width	50 mm	75 mm	50 mm	75 mm

L011982



KNC-PLC-K622-08DT

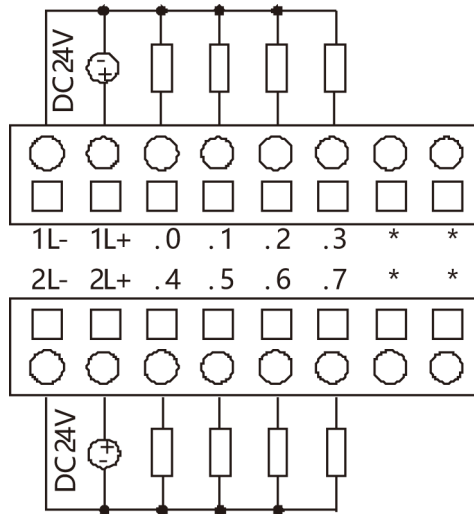

KNC-PLC-K622-16DT

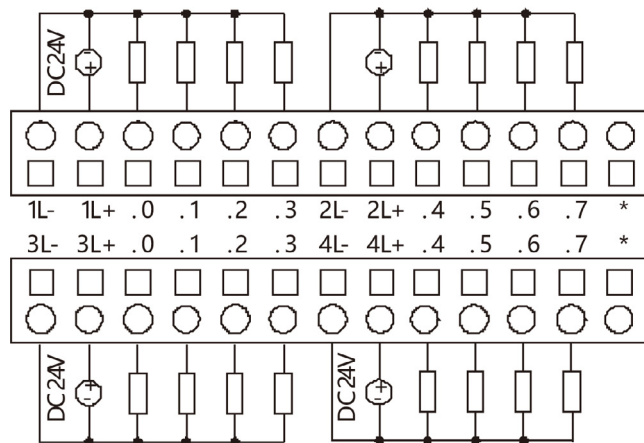

L011982